

cosmodrome rocketry

1:6 NIKE SMOKE

This kit is capable of use with high thrust motors. It is therefore strongly recommended that epoxy be used throughout the construction of this kit.

Parts List

A	1	Nose cone
B	1	Nose cone inlet
C	1	Nose cone exhaust
D	1	Nose cone covers
E	1	Anchor
F	1	Screw eye
G	1	Body tube
H	1	Shock cord mount
I	4	Fins
J	1	Forward centering ring
K	1	Aft centering ring
L	1	Motor mount tube
M	1	Washer
N	1	Nut
O	1	Engine retainer
P	1	Engine retainer stand off
Q	2	Launch lugs
R	2	Launch lug stand offs
S	1	Shock cord
T	1	Quick link
U	1	Parachute (not shown)
V	1	Decal sheet (not shown)

Cosmodrome Rocketry
 275 West St.
 Randolph, MA 02368
 (781) 961-1051
 www.cosmodromerocketry.com
 j9andmike@earthlink.net

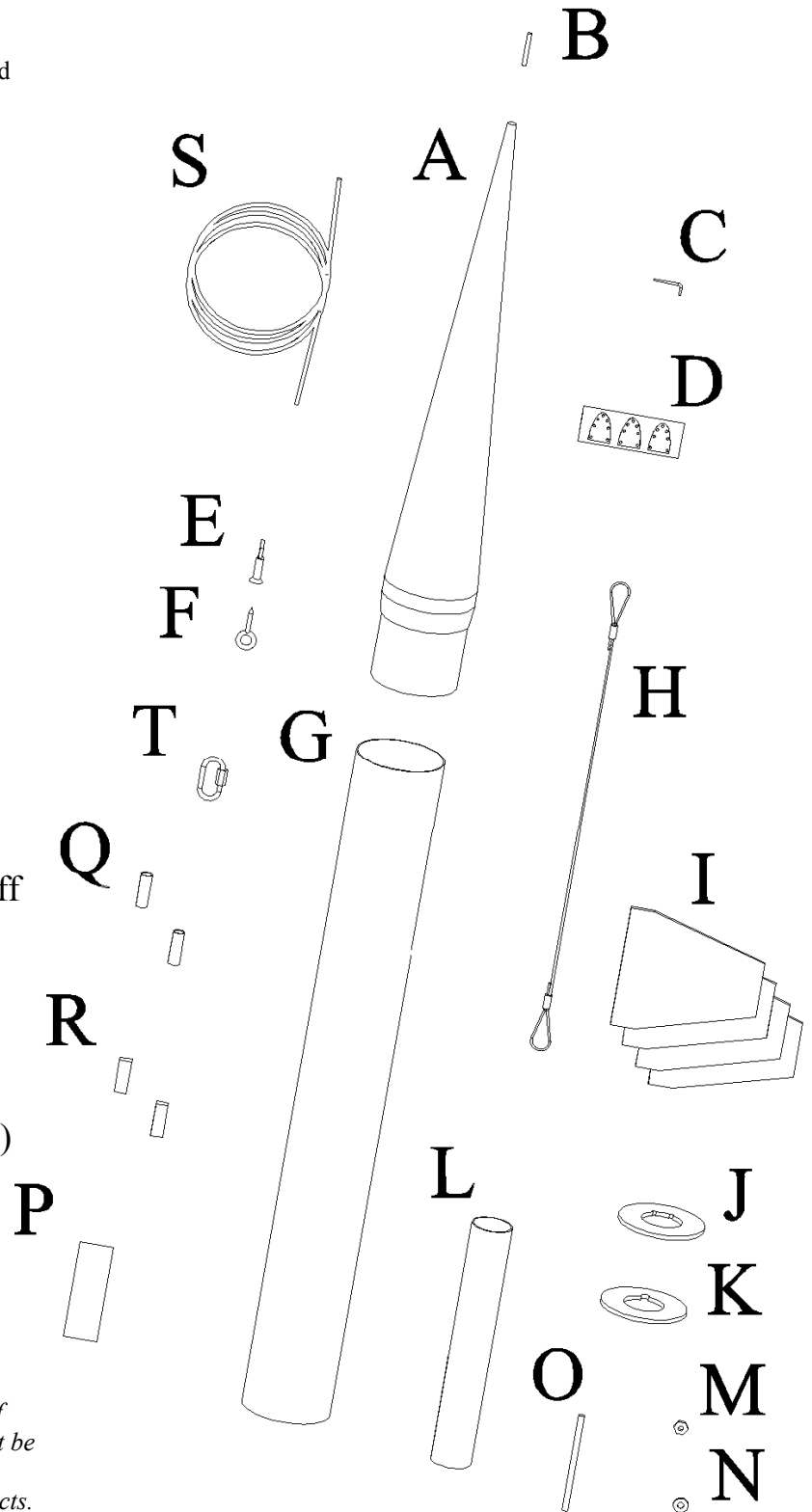

Since Cosmodrome Rocketry cannot control the use of our products once sold, Cosmodrome Rocketry cannot be held responsible for any personal injury or property damage resulting from the use or misuse of our products. The buyer assumes all risks and liabilities there from and accepts and uses our products on these conditions.

1. Draw a line down the side of the 29mm motor mount tube and mark the line 1/2" from both ends. Insert one end of the shock cord mount into the two holes in the forward centering ring. Slide the centering ring onto the motor mount tube. Position the centering ring onto one of the 1/2" marks on the tube as shown in figure 1. Epoxy the centering ring and shock cord mount to the tube.

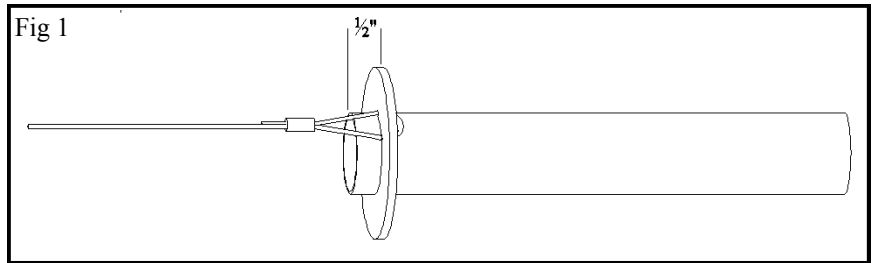

2. Slide the aft centering ring onto the tube until it is on the other 1/2" mark, such that the hole in the centering ring is lined up with the line on the motor mount tube. Without getting epoxy near the hole, epoxy the centering ring into place. Cut out two pieces of card stock, 1/8" x 1 1/2" and 1/8" x 1/2". Slide the engine retainer through the hole in the centering ring so that 3/4" extends past the end of the tube. Note: One end of the engine retainer is cut (painted), one is not (unpainted), position the uncut end aft and it will be easier to thread the nut on. Insert the two pieces of card stock between the tube and the engine retainer. Note: The card stock simply creates a space between the engine retainer and tube to allow for some reload cases enough clearance to fit. Epoxy the engine retainer to the tube, making sure that it is even with the line on the tube. Be careful not to get epoxy on the threads of the engine retainer that extend past the tube.

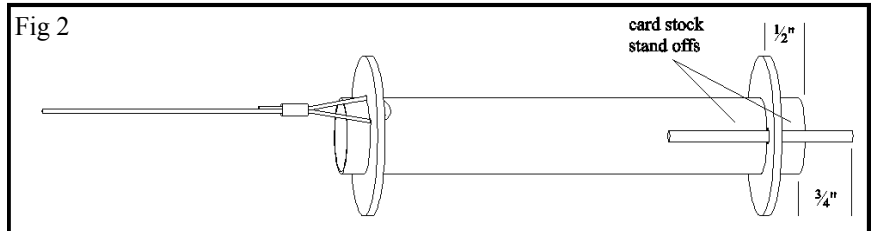

3. Draw guide lines on the fins as shown in figure 3. Apply masking tape to the area between the lines. This area will not be sanded. Sand the upper and lower parts of the fins so that they are knife-edged to a point.

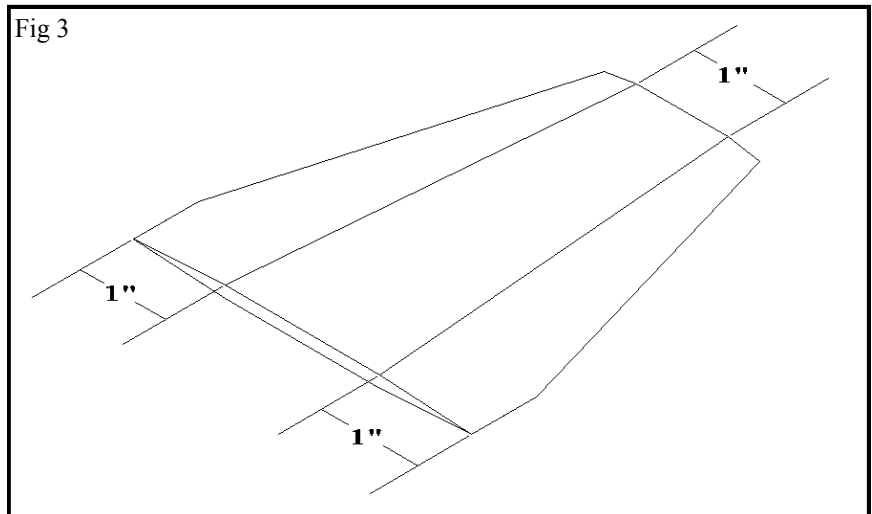

4. Using the body tube marking guide, mark the body tube at the 'Fin' and 'Lug' lines. Extend the fin line 5" up the tube. Extend the lug line the length of the tube. Mark the fin lines 1.1" (1 17/64") from the aft end of the tube. Place a fin on the tube so that the aft end of the fin tab is centered on a fin line and even with the 1.1" mark. Make sure that the forward end of the fin tab is centered on the fin line. Draw a line completely around the fin tab. Using an X-acto knife, cut out a slot for the fin tab by cutting on the inside of the outline. Carefully enlarge the slot, if necessary, until the fin tab fits snugly. Repeat for the other fins.

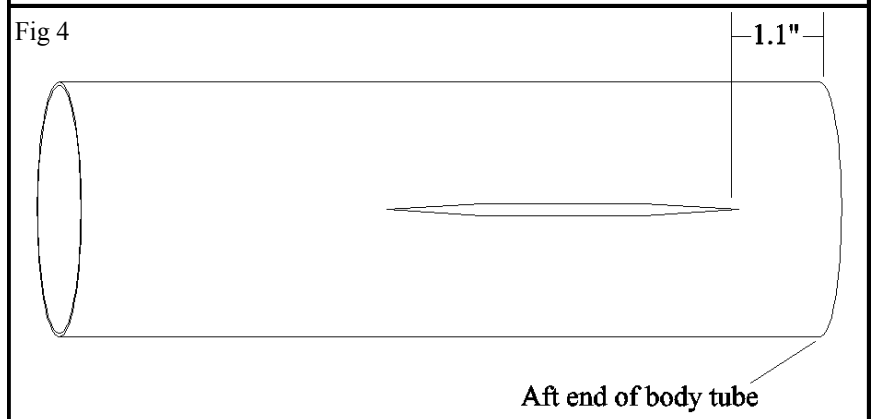

5. Apply a ring of epoxy to the inside of the body tube just forward of the fin slots. Push the motor mount assembly into the body tube until the aft end of the motor mount tube is even with the aft end of the body tube. Make sure the engine retainer is between two fin slots. Stand the assembly upright so that the epoxy can settle on the forward centering ring. Let the epoxy cure. Turn the assembly over and epoxy the aft centering ring to

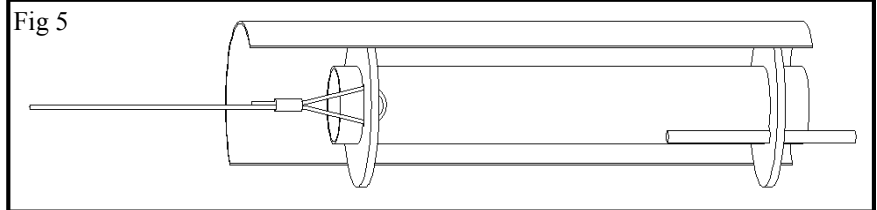

6. Apply epoxy to the motor mount tube through one of the fin slots. Also apply epoxy to the root edge of one fin. Insert the fin into the slot. Make sure that the fin is perpendicular to the body tube. Let the epoxy cure. Repeat for the other three fins. Fillet each fin.

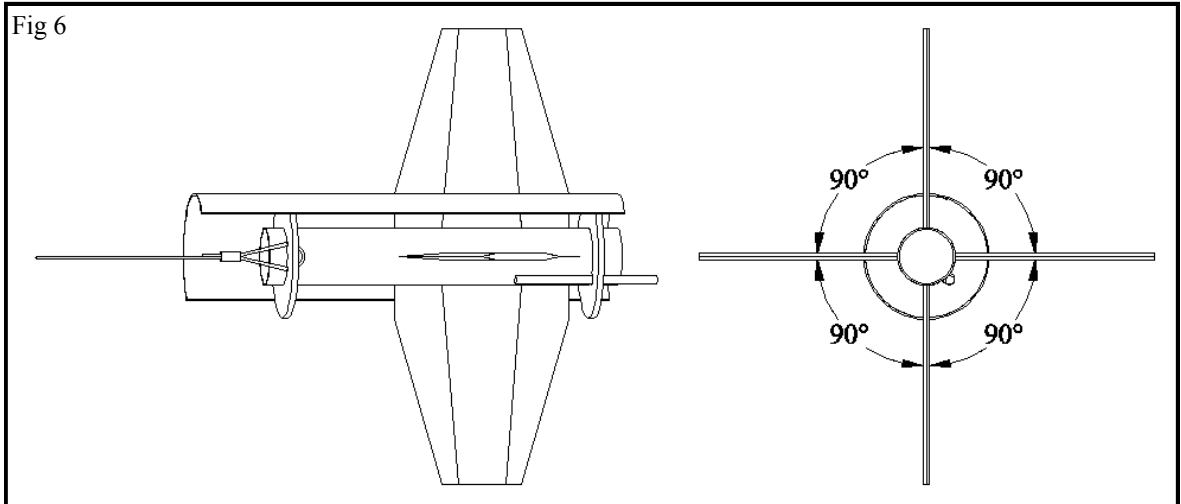

7. Epoxy the launch lug stand offs to the body tube on the 'lug' line. Place one of them 2 1/2" from the aft end of the body tube and the other 6" from the forward end. Place the stand offs with the wider side against the body tube. Epoxy a launch lug to each of the stand offs. Using a 1/4" launch rod, align the lugs so that the rod slides easily through them.

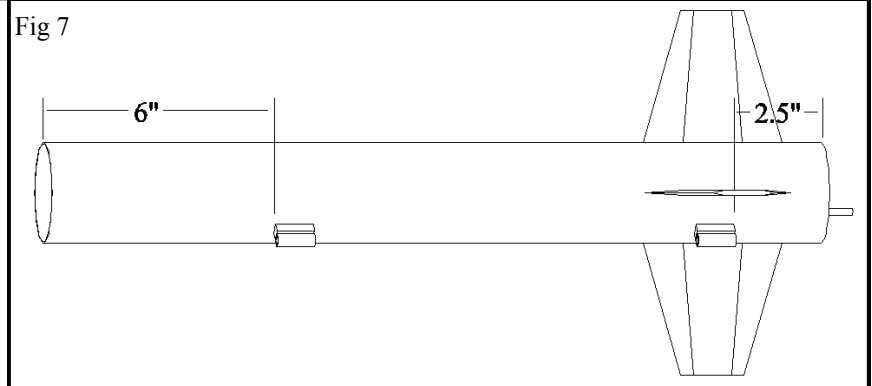

8. Thread the screw eye into the plastic anchor and remove. Apply a small amount of epoxy to the inside of the anchor and re-install the screw eye. Let the epoxy cure. Thread the screw eye/anchor into the base of the nose cone and remove. Fill the hole with epoxy and re-install the screw eye/anchor. Epoxy the nose cone inlet into the tip of the nose cone so that it extends 0.2" (13/64"). Cut out the nose cone template and wrap it around the nose cone. Mark the nose cone at the arrows (use a soft lead pencil or fine tip marker). Use a straight edge to connect the three sets of marks. Extend the lines to the base of the nose cone. Mark one of the lines 3.6" (3 39/64") from where the nose cone starts to taper in. Push the long end of the nose cone exhaust into the nose cone at this mark. Remove and epoxy the exhaust back in place so that the tip of the exhaust is 0.1" (7/64") from the nose cone. Cut the three nose cone covers from the plastic sheet. Sand the edges smooth. Epoxy the three covers on to the nose cone so that they are centered on the lines and the bottom edge of the cover is even with where the nose cone starts to taper in.

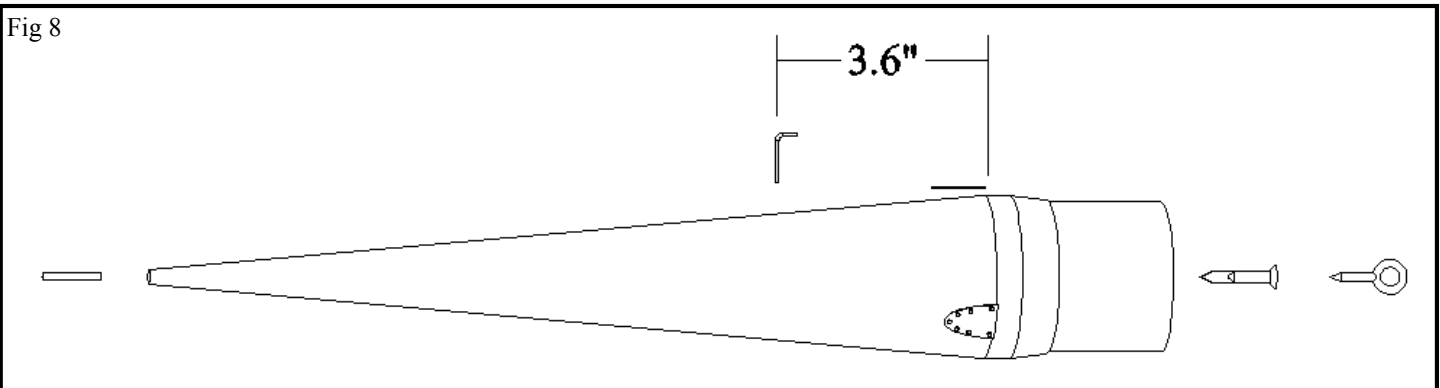

9. Feed one end of the shock cord through the screw eye and tie it to itself, forming a loop. Tie a loop in the shock cord one foot away from the nose cone, this is where the parachute is attached. Tie a loop in the other end of the shock cord. The quick link will go through this loop and attach to the shock cord mount.

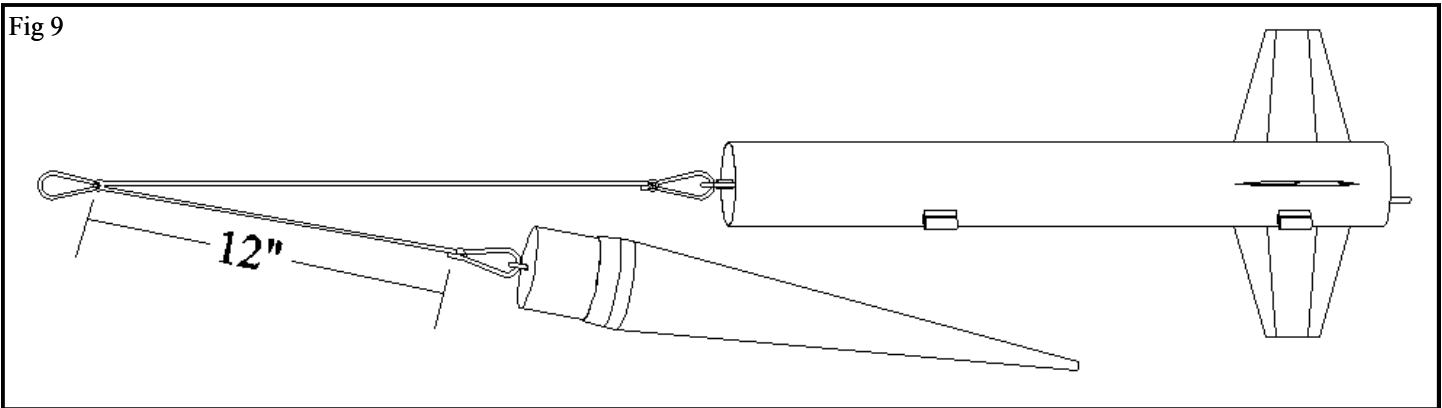

10. Finishing. This step is optional, but recommended. The standard paint scheme for the Nike Smoke is outlined here.

1. Fill in the spirals in the body tube.
 2. Coat the nose cone and fins with a sanding sealer to remove the grain of the wood.
 3. Coat the inside surfaces of the forward end of the body tube and the aft end of the motor mount tube with their CA. Sand until the motor and nose cone fit. This will help increase the life of your kit.
 4. Paint as follows:
 - a. One Fin: Fluorescent Yellow.
 - b. Three fins: Fluorescent Red.
 - c. Nose cone inlet: Black
 - d. Rest of the model: White
 5. Decals:
 - a. Cut out the two "UNITED STATES" decals as close to the letters as possible.
 - b. The first "UNITED STATES" decal should be placed on the body tube 8 1/4" from the aft end, centered between two fins, to the right of the yellow fin, reading "UP" the body tube.
 - c. The other one is placed on the opposite side of the body tube, reading "DOWN" the body tube.
 6. Apply a coat of clear gloss to protect the decals.
11. Flying.
1. Insert recovery wadding and loosely pack the parachute. Install the nose cone.
 2. Select a motor according to the most up-to-date recommended motor list available at <http://www.cosmodromerocketry.com>
 3. Disposable motors:
 - a. Build up a thrust ring on the aft end of the motor using 1/2" masking tape. Wrap tape around the motor until it is at least as thick as the motor mount tube.
 4. Reloadable motors:
 - a. Assemble the motor according to the manufacturer's instructions.
 - b. The thrust ring is built into the aft closure of the motor. No tape ring is needed.
 5. Install the motor into the motor mount tube.
 6. Slide the washer over the engine retainer.
 7. Thread the nut on the engine retainer and tighten against the motor.
 8. Install the igniter according to the manufacturer's instructions.

